

THE NEW VALUE FRONTIER



*THIEME*

Great for high  
pressure coolant | **KGBA-JCT**

# KGBA-JCT



**Excellent chip control and long tool life with high pressure coolant**

**Large holder lineup for turning, external grooving, cut-off and threading**

**Easy connection with high pressure hose and joint**

**Internal coolant provides longer tool life and excellent chip control**



**Shallow grooving**  
KGBA-JCT

Great for high pressure coolant

# JCT series

Excellent chip control and long tool life with high pressure coolant

Large holder lineup for turning, external grooving, cut-off and threading

## Special coolant hole design

Unique coolant system for various machining applications

○ : Coolant hole



**Turning**  
Double clamp-JCT



**External shallow grooving**  
KGBA-JCT



**External grooving**  
KGD-JCT



**Threading**  
KTN-JCT

## Advantages of internal coolant

Discharges coolant towards the cutting edge

Internal coolant provides longer tool life and excellent chip control

### Extended tool life

**Wear resistance comparison** (In-house evaluation)

Internal coolant (7 MPa)

External coolant (0.4 MPa)



Cutting conditions:  $V_c = 250$  m/min,  $f = 0.3$  mm/rev,  $a_p = 2$  mm, wet, CNMG120408 type, workpiece: 34CrMo4, external turning after machining 42.2 min

### Improved chip control

**Chip control comparison** (In-house evaluation)

Internal coolant (7 MPa)

External Coolant (0.4 MPa)



Cutting conditions:  $V_c = 200$  m/min,  $f = 0.05$  mm/rev,  $a_p = 0.5$  mm, wet, DNMG150408 type, workpiece: 15CrMo4, external turning

# Easy coolant connections

## Easy connection with high pressure hose and joint

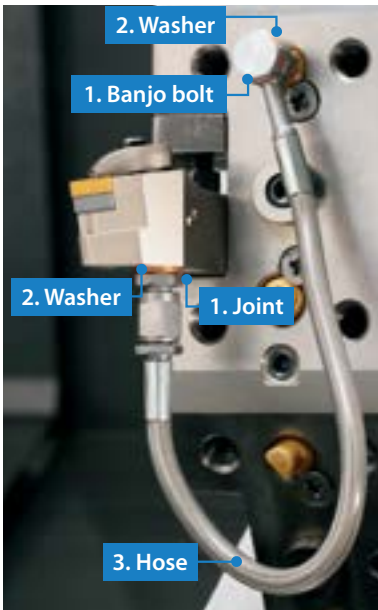

- Even without a high pressure pump, internal coolant can be used at a normal pressure
- Banjo bolt available for angled hose connection. Can be used in a variety of machines

### Piping installation guide

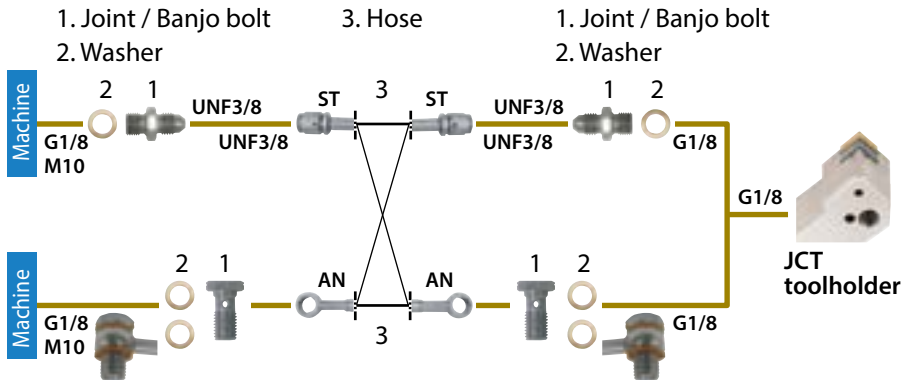

## Piping parts

### Optional piping parts available

Choose from parts below to match your machine specifications

1. Joint / Banjo bolt × 2 2. Washer × 2-4 3. Hose × 1

#### 1. Joint / Banjo bolt

Applicable pressure: ~ 30 MPa

Shape	Description	Available	Thread standard	
			Thread connection to the machine	
	J-G1/8-UNF3/8	●	G1/8	
	J-M10X1.5-UNF3/8	●	M10X1.5	
Banjo bolt (For the angle hose)	BB-G1/8	●	G1/8	
	BB-M10X1.5	●	M10X1.5	

#### 2. Washer

Applicable pressure: ~ 30 MPa

Shape	Description	Available
	WS-10	●

\* Use 2 washers for a banjo bolt

#### 3. Hose

Applicable pressure: ~ 30 MPa

Shape	Description	Available	Thread standard		Dimensions (mm)
					L
	HS-ST-ST-200	●	UNF3/8	UNF3/8	200
	HS-ST-ST-250	●			250
	HS-ST-AN-200	●	UNF3/8	Banjo bolt	200
	HS-ST-AN-250	●			250
	HS-AN-AN-200	●	Banjo bolt	Banjo bolt	200
	HS-AN-AN-250	●			250

### Precautions

1. Make sure machine door is completely closed before use of these parts.
2. Use appropriate seal for the male thread of the piping parts and make sure the connection is secure. Use plugs to seal off unused coolant holes.
3. Connect and fasten the coolant hose firmly.
4. The use of copper washers may cause leakage but will have no effect on the performance.
5. Commercial piping parts can be used if the thread standards are same. Check the applicable pressure before use.
6. Regularly changing the coolant filter is recommended.

Great for high pressure coolant, toolholder for shallow grooving

# KGBA-JCT

KGBA-JCT can direct coolant closer to the cutting edge from the top of the insert  
Excellent chip control and longer tool life

## 1 Excellent chip control

Ground chipbreaker

Chip control comparison (In-house evaluation)

Internal coolant provides excellent chip control  
High-pressure coolant is more effective

Alloy steel - 20Cr4

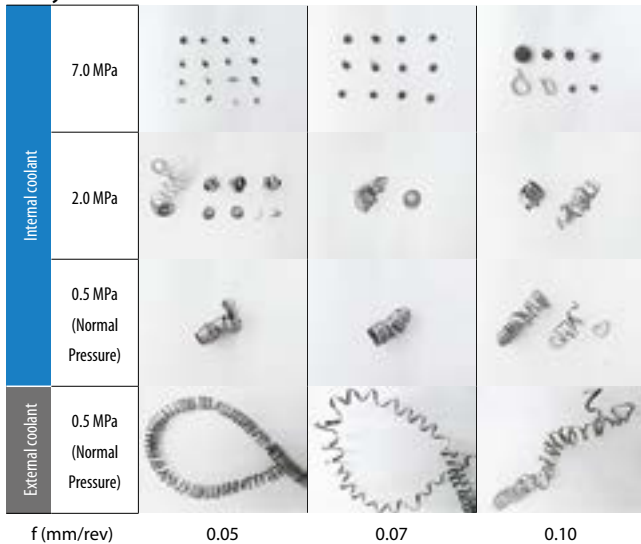

Stainless steel - X5CrNi1810

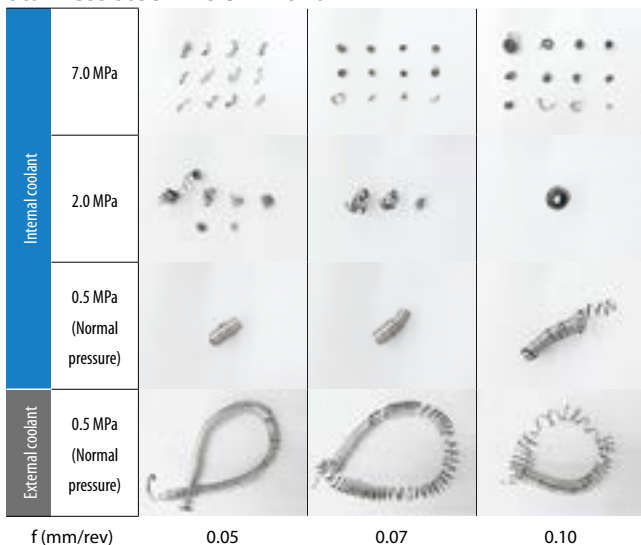

Cutting conditions: Vc = 150 m/min (Alloy steel) / 100 m/min (Stainless steel),  
f = 0.05~0.1 mm/rev, Groove depth = 2 mm, wet  
KGBAR2525K22-15JCT, GBA43R200-020 (PR1215)

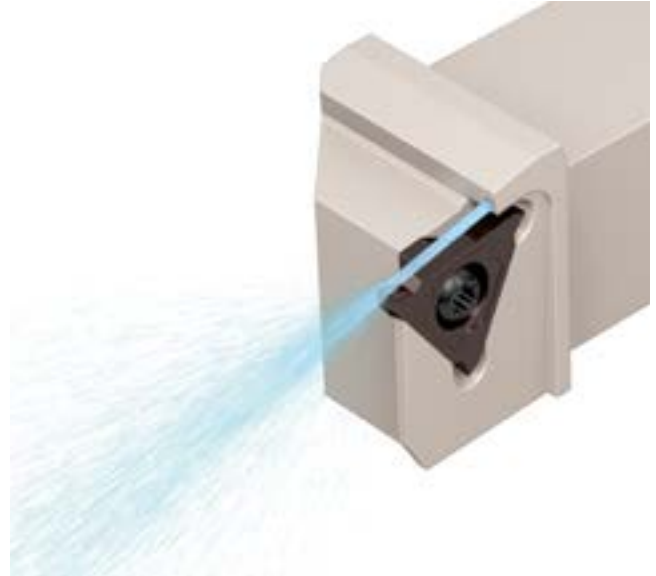

### Coolant hole

Coolant is discharged to the cutting edge. Prevents coolant stream spreading which slows the coolant flow

### Coolant direction

Sufficient coolant between the chipbreaker and the chips. Stable chip curls and sufficient cooling of the insert

## 2 Superior cooling action improves tool life

Internal coolant provides better corner wear resistance

Wear resistance comparison (In-house evaluation)

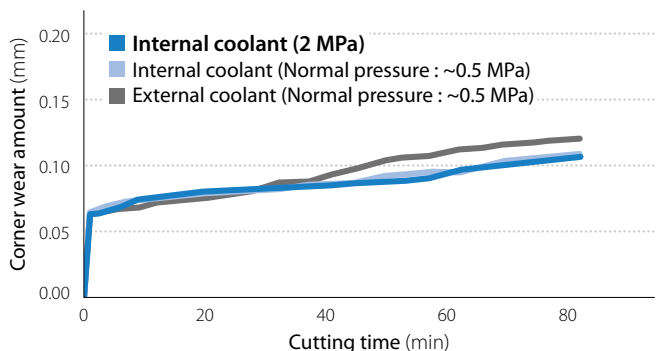

Cutting conditions: Vc = 150 m/min, f = 0.07 mm/rev, groove depth = 2 mm, wet  
KGBAR2525K22-15JCT, GBA43R200-020 (PR1215) Workpiece: 34CrMo4

# KGBA-JCT (Toolholder for shallow grooving)

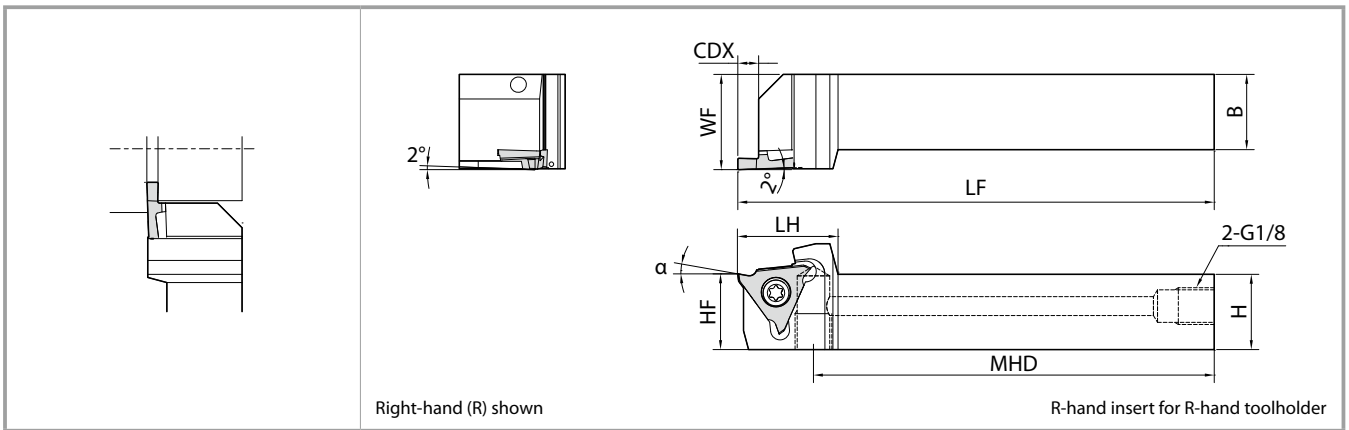

Right-hand (R) shown

R-hand insert for R-hand toolholder

## Toolholder dimensions

Description	Availability		Dimensions (mm)									Spare parts				Applicable inserts	
	R	L	H	HF	B	LF	LH	WF	CDX	MHD	Clamp screw	Wrench		Plug			
KGBA <sup>R/L</sup> 2020K-16JCT	●	●	20	20	20	125	24.0	25	2.5	107.5	SB-4085TR	FT-15	-	HSG1/8x8.0	GBA32 <sup>R/L</sup> type		
2525K-16JCT	●	●	25	25	25			30									
2020K22-15JCT	●	●	20	20	20		26.5	25	4		105	SB-5085TR	-			LTW-20	GBA43 <sup>R/L</sup> type
2525K22-15JCT	●	●	25	25	25			30									
2020K22-25JCT	●	●	20	20	20		26.5	25	5.5		105	SB-5085TR	-			LTW-20	
2525K22-25JCT	●	●	25	25	25			30									
2020K22-35JCT	●	●	20	20	20		26.5	25	5.5		105	SB-5085TR	-			LTW-20	
2525K22-35JCT	●	●	25	25	25			30									

Please see P.2 for piping parts.

CDX shows the distance from the toolholder to the cutting edge. Available groove depth: "CDX" of insert.

KGBA-JCT toolholder is screw clamp type

Regarding rake angle after installation of GBA (α), please see the KYOCERA general product catalog or GBA brochure

● : Available

## Recommended grade for steel

General purpose : PR1215

Surface finish oriented : TN620

For stable machining : PR1625

**PR1625**

**NEW**



Cemented carbide grade with high stability and MEGACOAT NANO with excellent adhesion resistance provides high toughness and high hardness

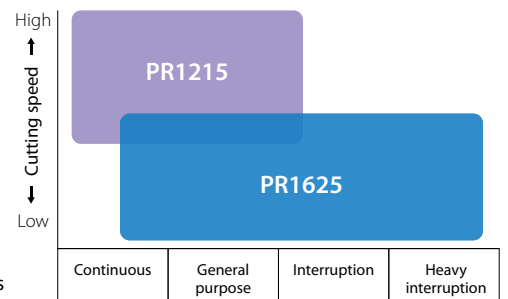

Long tool life is achieved in the interrupted grooving including drum and shaft of transmission engine parts.

# KGBA-JCT applicable inserts

## Ground chipbreaker

NEW

Ground chipbreaker	P Carbon steel / Alloy steel		M Stainless steel		K Cast iron		N Non-ferrous material		S Titanium alloy		H Hardened material (~40HRC)			
	●		○		●		●		●		○			
	●		○		●		●		●		○			
Description	Dimensions (mm)			MEGACOAT cermet	Cermets			PVD coated carbide			Cermet	Applicable toolholders		
	CW	CDX	RE		MEGACOAT	MEGACOAT	MEGACOAT	PVD	PVD	PVD			Carbide	
	Edge width (W)	Available grooving depth	Corner-R	PV7040	TC40N	TN90	PR1215	PR1625	PR1115	PR905	PR930	KW10		
GBA32 <sup>R/L</sup>	033-005	0.33	0.8						●	●			1	
	050-005	0.50	1.0			R						●		
	050-005	0.50	1.2											
	075-005	0.75		0.05	●	R	●	●	●	R	●	●		
	095-005	0.95				●	●	●			●	●		
	100-005	1.00			●	●	●	●		R	●	●		
	110-005	1.10	2.0						●	R				
	120-005	1.20							●					
	125-020	1.25			●	●	●	●				●		●
	130-020	1.30							R					
	140-020	1.40	2.5					●	●	R				
	145-020	1.45	2.0				●					●		
	150-020	1.50	2.0		●		●					●		
	160-020	1.60	2.5	0.2				●	●	R				
	170-020	1.70	2.0						●					
	175-020	1.75	2.0				●							●
	200-020	2.00	2.5		●		●	●	●	●	●	●		
	225-020	2.25							●					
	250-020	2.50					●	●	●		●	●		
	300-020	3.00					●	●	●	●	●	●		
GBA43 <sup>R/L</sup>	125-010	1.25	2.0	0.1			●	●					2	
	125-020	1.40	3.5	0.2	●	●	●	●		R	●	●		
	140-020	1.40	2.0			●	●			R				
	145-020	1.45				●	●				●			
	150-010	1.50		0.1			●	●						
	150-020	1.50			●	●	●	●	●	●	●	●		
	170-020	1.70					●	●						
	175-020	1.75	3.5	0.2		R	●	●	●	●	●	●		
	185-020	1.85				●	●	●			●	●		
	195-020	1.95								R				
	200-010	2.00		0.1				●	●					
	200-020	2.00			●	●	●	●	●	●	●	●		
	225-020	2.25		0.2				●	●		●	●		
	230-020	2.30				●	●	●			●	●		
	250-010	2.50	5.0	0.1				●						
	250-030	2.50	4.0		●	●	●					●		
	265-030	2.65	4.0	0.3		R	●					●		
	280-030	2.80	4.0			R	●					●		
	300-010	3.00	5.0	0.1				●						
	300-030	3.00	4.0		●	●	●					●		
325-030	3.25	5.0	0.3				●	●	R	●				
330-030	3.30	4.0			●	●					●			
350-010	3.50		0.1				●							
350-030	3.50		0.3		●	●			●	●	●			
400-010	4.00		0.1				●							
400-040	4.00			●	●	●	●	●	●	●	●			
430-040	4.30		0.4		●	R	●			R	●			
450-040	4.50				R	R	●				●			
480-040	4.80					R	●				●			

Ground chipbreaker Sharp edge type	P Carbon steel / Alloy steel		M Stainless steel		K Cast iron		N Non-ferrous material		S Titanium alloy		H Hardened material (~40HRC)	
	●		○		●		●		●		○	
	●		○		●		●		●		○	
Description	Dimensions (mm)			MEGACOAT cermet	Cermets	PVD coated carbide	Cermet	Applicable toolholders				
	CW	CDX	RE									
	Edge width (W)	Available grooving depth	Corner-R									
GBA32 <sup>R/L</sup>	050-005F	0.50	1.0					1				
	075-005F	0.75		0.05								
	095-005F	0.95										
	100-005F	1.00										
	125-020F	1.25	2.0									
	145-020F	1.45										
	150-020F	1.50										
	175-020F	1.75										
	200-020F	2.00	2.5									
	250-020F	2.50										
GBA43 <sup>R/L</sup>	125-020F	1.25	2.0					2				
	145-020F	1.45										
	150-020F	1.50										
	175-020F	1.75	3.5	0.2								
	185-020F	1.85										
	200-020F	2.00										
	230-020F	2.30										
	250-030F	2.50	4.0	0.3								
	265-030F	2.65										
	280-030F	2.80										
300-030F	3.00											
330-030F	3.30	5.0	0.4				4					
350-030F	3.50											
400-040F	4.00											
430-040F	4.30											
450-040F	4.50											
480-040F	4.80											

**Applicable toolholders**  
 1: KGBAR ... 16 JCT type  
 2: KGBA <sup>R/L</sup> ... 22-15 JCT type  
 3: KGBA <sup>R/L</sup> ... 22-25 JCT type  
 4: KGBA <sup>R/L</sup> ... 22-35 JCT type

For more details on cutting conditions, please see the KYOCERA general product catalog or GBA brochure  
 ● : Available R: Available (Right-hand only)

# KGBA-JCT applicable inserts

## Molded chipbreaker

NEW

Molded chipbreaker GM chipbreaker		P	Carbon steel / Alloy steel	●	●	●	●	●	●						
		M	Stainless steel				●	●	●						
		K	Cast iron				●								
		N	Non-ferrous material												
		S	Titanium alloy												
		H	Hardened material (~40HRC)				●								
Description	Dimensions (mm)			Cemet	MEGACOAT	MEGACOAT NANO	Applicable toolholders								
	CW	CDX	RE	TN620	PR1215	PR1625									
	Edge width (W)	Available grooving depth	Corner-R												
GBA43 <sup>R/L</sup>	140-010GM	1.40	0.1	●	●		2								
	150-020GM	1.50	0.2	●	●	●									
	175-020GM	1.75		●	●										
	185-020GM	1.85		●	●										
	200-020GM	2.00		●	●	●									
	230-020GM	2.30		●	●										
	250-030GM	2.50	0.3	●	●	●				3					
	265-030GM	2.65		●	●										
	300-030GM	3.00		●	●	●									
	330-030GM	3.30		●	●										
	350-030GM	3.50		●	●										
	400-040GM	4.00	0.4	●	●	●							4		

Molded chipbreaker MY chipbreaker		P	Carbon steel / Alloy steel	○	●	●	○					
		M	Stainless steel				●					
		K	Cast iron				●					
		N	Non-ferrous material									
		S	Titanium alloy									
		H	Hardened material (~40HRC)				●					
Description	Dimensions (mm)			Cemet	MEGACOAT	PVD coated carbide	Applicable toolholders					
	CW	CDX	RE	TN620	PR1215	PR930						
	Edge width (W)	Available grooving depth	Corner-R									
GBA43 <sup>R/L</sup>	175-020MY	1.75	0.2	●	●	●	2					
	185-020MY	1.85	0.2	●	●	●						
	200-020MY	2.00		●	●	●						
	230-020MY	2.30		●	●	●						
	250-030MY	2.50		●	●							
	250-030MY	2.50		0.3	●	●			●	3		
	265-030MY	2.65	●		●							
	265-030MY	2.65	●		●	R						
	300-030MY	3.00	●		●	●						
	300-030MY	3.00	●		●	●						
	330-030MY	3.30	0.4	●	●	●			4			
	330-030MY	3.30	0.4	●	●	●						
	350-030MY	3.50	0.4	●	●	●						
	400-040MY	4.00	0.4	●	●	●						

## Full-R

NEW

Full-R		P	Carbon steel / Alloy steel	●	○	●	●	○	○				
		M	Stainless steel			●	●	○	○				
		K	Cast iron					○	○				
		N	Non-ferrous material						●				
		S	Titanium alloy						●				
		H	Hardened material (~40HRC)			●		○	○				
Description	Dimensions (mm)			MEGACOAT Cemet	Cemet	MEGACOAT	MEGACOAT NANO	PVD Coated carbide	Carbide	Applicable toolholders			
	CW	CDX	RE	PV7040	TN620	TN90	PR1215	PR1625	PR1115		PR905	PR930	KW10
	Edge width (W)	Available grooving depth	Corner-R										
GBA32R	200-100R	2.00	1.00					R	R	1			
	300-150R	3.00	1.50					R	R				
GBA43 <sup>R/L</sup>	100-050R	1.00	0.50	●		●	●			●	●	2	
	150-075R	1.50	0.75	●		●	●		R	●	●		
	200-100R	2.00	1.00	●		●	●			●	●		
	250-125R	2.50	1.25			●	●			●	●		
	300-150R	3.00	1.50			●	●		●	●	●		
	400-200R	4.00	2.00			R	●			●	●		
	400-200R	4.00	2.00										
GBA43 <sup>R/L</sup>	100-050RF	1.00	0.50		●								
	150-075RF	1.50	0.75		●								
	200-100RF	2.00	1.00		●								
	250-125RF	2.50	1.25		●								
	300-150RF	3.00	1.50		●								
	400-200RF	4.00	2.00		R								

GBA43<sup>R/L</sup> ...RF: Sharp Edge Type

## CBN / PCD

1-Edge (CBN / PCD)		P	Carbon steel / Alloy steel						
		M	Stainless steel						
		K	Cast iron						
		N	Non-ferrous material			●			
		S	Titanium alloy			●			
		H	Hardened material (~40HRC)		○	●			
Description	Dimensions (mm)			CBN		PCD		Applicable toolholders	
	CW	CDX	RE	KBNS10	KBNS25	KPD001	KPD010		
	Edge width (W)	Available grooving depth	Corner-R						
GBA32R	125-010	1.25	0.1				R	1	
	150-010	1.50	2.0				R		
GBA43 <sup>R/L</sup>	125-010	1.25	0.1				●	2	
	125-020	1.25	0.2	R	●				
	150-010	1.50	0.1			●	●		
	150-020	1.50	0.2	●	●				
	200-010	2.00	0.1			●	●		
	200-020	2.00	0.2	●	●				
	250-010	2.50	0.1			●	●		
	250-020	2.50	0.2	●	●				
	300-010	3.00	0.1			●	●		
	300-020	3.00	0.2	●	●				

### Applicable toolholders

- 1: KGBAR ... 16 JCT type
- 2: KGBA<sup>R/L</sup> ... 22-15 JCT type
- 3: KGBA<sup>R/L</sup> ... 22-25 JCT type
- 4: KGBA<sup>R/L</sup> ... 22-35 JCT type

For more details on cutting conditions, please see the KYOCERA general product catalog or GBA brochure  
 ● : Available R: Available (Right-hand only)

Excellent chip control and long tool life with high pressure coolant

Great for high pressure coolant

# JCT series

- Large holder lineup for turning, external grooving, cut-off and threading
- Easy connection with high pressure hose and joint
- Internal coolant provides longer tool life and excellent chip control



JCT brochure

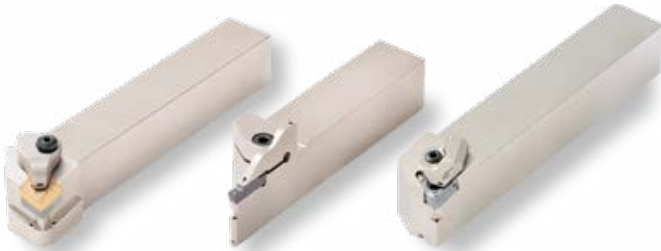

Small tools with internal coolant supply

Provides long tool life and excellent chip control

# JCT series

## for small parts machining

- Great for high pressure coolant; up to 20 MPa
- Large holder lineup for turning, external grooving and cut-off



JCT small parts machining  
brochure

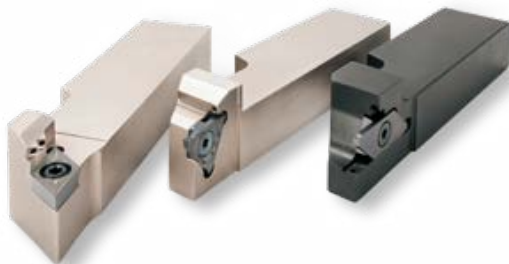

[www.kyocera-unimerco.com](http://www.kyocera-unimerco.com)

The information contained in this brochure is current as of April 2019.  
Duplication or reproduction of any part of this brochure without approval is prohibited.  
TZE00148  
© 2019 KYOCERA Corporation

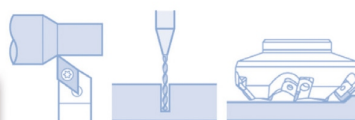

**THIEME**  
CNC-Werkzeugtechnik

**Wir sind Ihr Optimierungsexperte  
für Zerspanungs-, Spann- und Messtechnik**



Königsfelder Str. 33  
58256 Ennepetal  
[www.thieme-werkzeuge.de](http://www.thieme-werkzeuge.de)

Tel. 02333-9786-0  
Fax 02333-9786-49  
[info@thieme-werkzeuge.de](mailto:info@thieme-werkzeuge.de)