

THE NEW VALUE FRONTIER



THIEME
CNC-Werkzeugtechnik



DYNAMIC-BAR

Streamlined Head for

- Improved chip evacuation
- Reduced chattering
- Stable machining

Stromlinienförmiger Spankanal für

- Verbesserte Spanabfuhr.
- Verringerte Vibrationsneigung.
- Stabile Bearbeitung.

Tête aérodynamique pour

- Meilleure évacuation de copeaux.
- Réduction du broutage.
- Haute rigidité.

Testa aerodinamica per ottenere

- Evacuazione del truciolo.
- Riduzioni delle vibrazioni.
- Stabilità in lavorazione.

Streamlined Head driven by the latest computer simulation technology

Tool holder design through stress analysis:
Maximum structural thickness for high tool holder rigidity.
Controls chattering to achieve stable machining.

Large chip pocket:
Exhibits superior chip evacuation.

Gestaltung der Spankammer mit computergestützter Simulationstechnologie:

Durch Belastungsanalysen optimierte Bohrstange, ermöglicht eine größtmögliche Stabilität der Bohrstange und reduziert die Vibrationsneigung bei gleichbleibender stabiler Bearbeitung.

Große Spankammer ermöglicht hervorragende Spanabfuhr.

Concept du logement développé par CAO:

Rigidité accrue par un renforcement maximal de la structure de l'outil. Moins de vibrations pour un usinage stable.

Large poche pour une meilleure évacuation des copeaux.

Bareno progettato attraverso il concetto di analisi FEM:

Massimo spessore strutturale per ottenere un'alta rigidità ed una riduzione delle vibrazioni con conseguente stabilità di lavorazione.

Largo canale di evacuazione truciolo per un miglior controllo dello stesso.

■ Comparison of pocket length Vergleich Spankammerlänge Comparaison de poche copeaux Confronto della lunghezza del canale di evacuazione

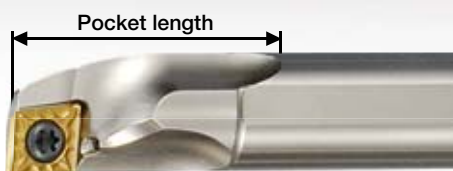

■ Chip evacuation direction Spanabfuhr Richtung Direction du flux des copeaux Direzione evacuazione truciolo

C•T•W-type insert



D•V-type insert

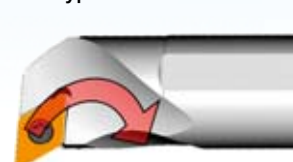

Description Bezeichnung Désignation Descrizione	Pocket length Spankammer Poche Copeaux Lunghezza del canale di evacuazione	
	Dynamic-Bar	Competitor A
A16-SCLPR09-18 Type	37	29
A20-SCLCR09-22 Type	48	32

Superior chip evacuation (External coolant)
Ausgezeichnete Spanabfuhr (Außenkühlung)
Meilleure évacuation des copeaux (Arrosage extér)
Evacuazione truciolo superiore (Refrigerante esterno)

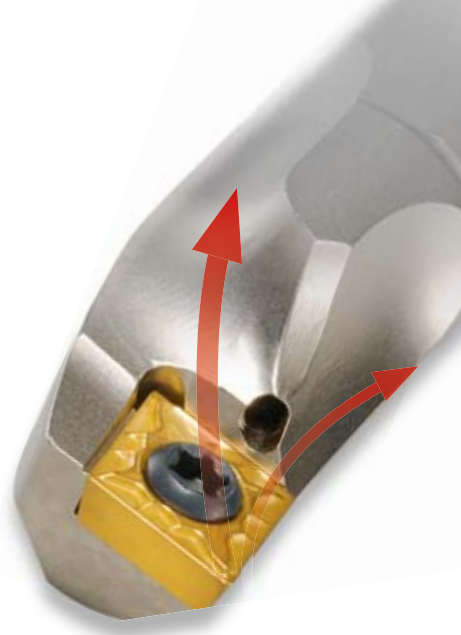
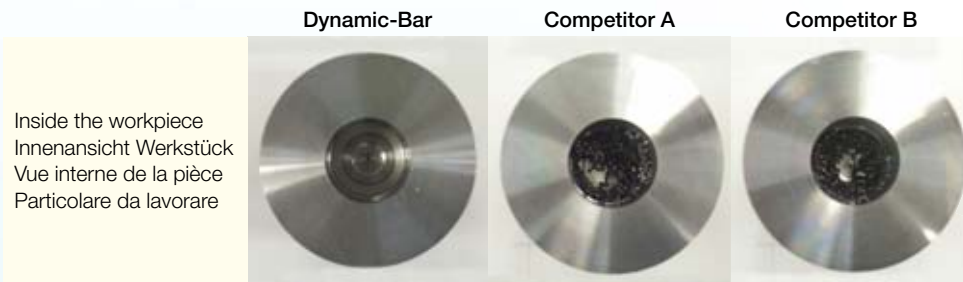

In the products of competitors A and B chips remain inside the workpiece, but chips from the Dynamic-Bar are all evacuated from the workpiece.
 Im Gegensatz zum Wettbewerb verbleiben beim Einsatz der Dynamic-Bar keine Späne im Werkstück. Geringe Ratterneigung bei der Dynamic-Bar.
 Pour les concurrents A et B les copeaux sont refoulés dans l'alésage, alors qu'avec la Dynamic-Bar, les copeaux sont tous évacués vers l'extérieur de la pièce.
 Nei baren dei concorrenti A e B, il truciolo rimane dentro al pezzo in lavorazione, ma con l'uso della Dynamic-Bar è evacuato completamente.

Anti chatter vibration performance | Vergleich Vibrationsneigung
Broutage et vibrations réduits | Prestazione di Anti vibrazione

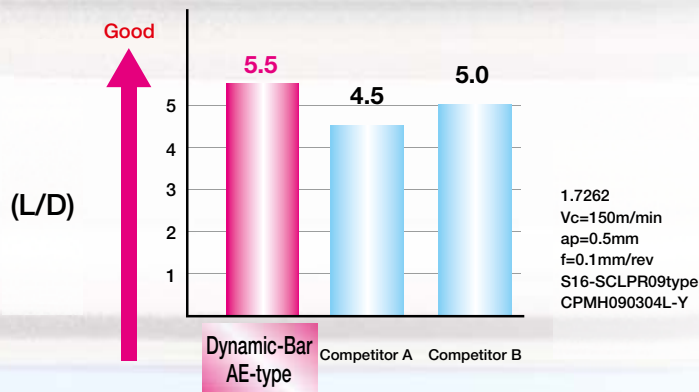

Minimum of chattering by the Dynamic-Bar
 Geringste Neigung zur Vibration mit Dynamic-Bar
 Moins de vibrations avec la Dynamic-Bar
 Le vibrazioni di Dynamic-Bar sono minime

Comparison of surface finish | Vergleich der Oberflächen
Comparatif d'état de surface | Confronto finitura superficiale

	Dynamic-Bar	Competitor A	Competitor B
Surface roughness Oberflächen Rauigkeiten Etat de surface Rugosità superficiale	 Ra=0.4µm Rz=2.3µm	 Ra=0.6µm Rz=3.6µm	 Ra=3.4µm Rz=14.0µm
Oscillatory waveform Schwingsungsverlauf Ondulation Movimento oscillatorio dell'onda			

Vibration of the Dynamic-Bar was minimal even at high cutting speeds, enabling stable machining.

Auch bei höheren Schnittgeschwindigkeiten war die Vibrationsneigung sehr gering und ermöglichte eine Stabile Bearbeitung.

Vibration minimale avec la Dynamic-Bar même à vitesse élevée, d'où un usinage stable.

Le vibrazioni della Dynamic-bar sono minime anche ad alte velocità di taglio permettendo stabilità in lavorazione.

1.7262
 Vc=210m/min
 ap=0.5mm
 f=0.1mm/rev
 A16Q-SCLPR09-18type
 CPMT090304XP (PV7020)
 L/D=4
 External coolant

Direction of vibration measurement
 Richtung der Vibrationsmessung
 Mesure des vibrations
 Direzione della misura di vibrazione

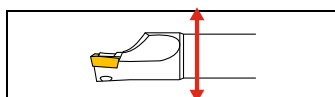

Indexability
Indexierbarkeit
Indexabilité
Indexabile

In particular, the AE type Dynamic-Bar maintains high cutting edge positional accuracy through the use of a special alloy, thereby achieving high precision machining.

Speziell die Dynamic-Bar AE Ausführung erreicht eine hohe Lagegenauigkeit und ermöglicht hochpräzise Bearbeitungen.

La Dynamic-Bar type AE confère une très grande précision de positionnement et une grande rigidité, en particulier lors d'usinage d'aciers alliés.

In particolare, la AE Dynamic-Bar ha un'ottima ripetibilità di riposizionamento dell'inserto nella propria sede dovuta ad un'adeguata scelta del materiale costruttivo costituito da una lega speciale. Il tutto consente lavorazioni davvero precise.

* X-Achse Auslenkung | Axe X flexion | Scostamento asse X

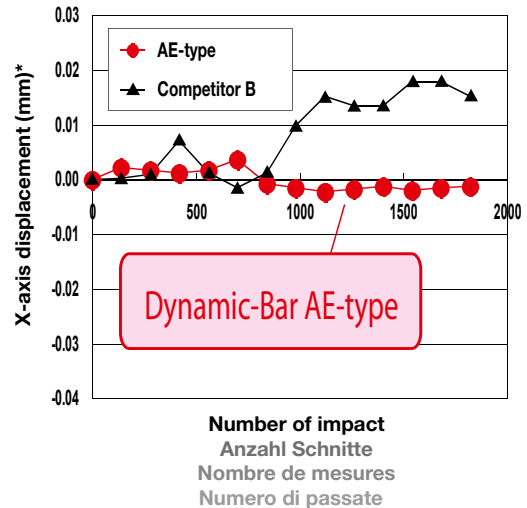

1.7220
Vc=180m/min, ap=2mm
f=0.2mm/rev
S/A16Q-SCLPR09-18type
CPMH090308(CA5525)
L/D=4
External coolant

Direction of vibration measurement
Richtung der Vibrationsmessung
Mesure des vibrations
Direzione della misura di vibrazione

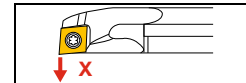

Advantages of Dynamic-Bar (D and V type insert)
Vorteile der Dynamic-Bar (D und V WSP Typ)
Avantages de la Dynamic-Bar (D et V type plaquette)
Vantaggi della Dynamic-Bar (D e V tipo inserto)

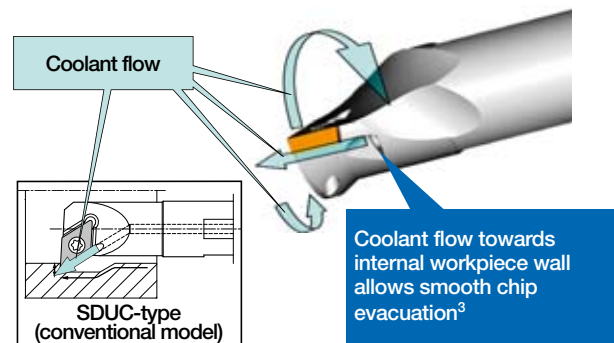
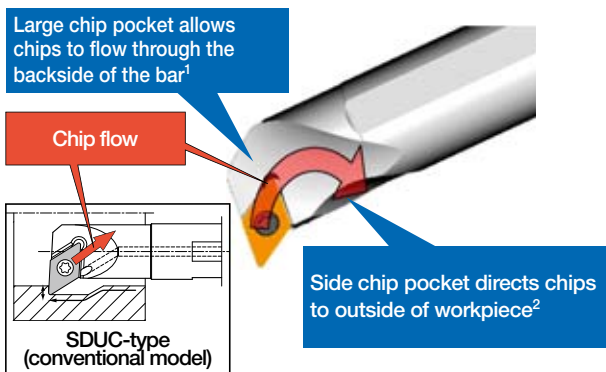

¹ Große Spankammer ermöglicht Spanabfuhr über die Rückseite der Bohrstange.

¹ La poche copeaux sur dimensionnée entraîne les copeaux vers l'arrière de l'outil.

¹ Una larga tasca per lo smaltimento del truciolo consente l'evacuazione dalla parte posteriore del bareno.

² Seitliche Spankammer leitet den Span aus der Bohrung.

² La poche latérale dirige les copeaux hors de la pièce.

² Le tasche laterali dirigono il truciolo fuori dal pezzo in lavorazione.



³ Gleichmäßige Spanabfuhr bei Zuführung der Kühlflüssigkeit zur Innenwand des Werkstücks.

³ L'orientation du jet vers l'intérieur de la pièce permet une excellente évacuation des copeaux.

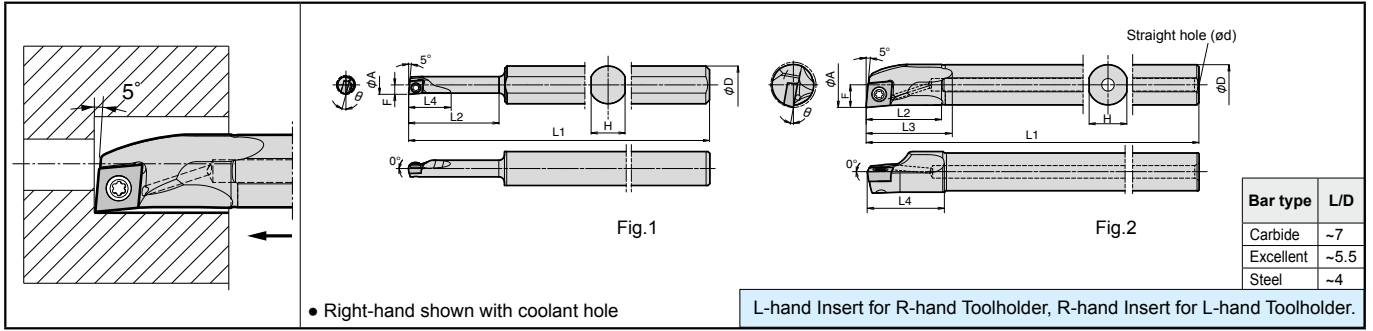
³ Il foro della lubrificazione interna è inclinato nella direzione del pezzo in lavoro.

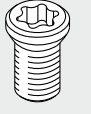

● Toolholder Dimensions

Description	Stock		Min. Bore Dia. øA	Dimension (mm)							θ	Standard Corner-R (rε)	Coolant Hole	Drawing	Spare Parts					
	R	L		øD	H	L1	L2	L3	L4	F					Clamp Screw	Wrench				
	 																			
Excellent Bar	S10H-SCLC%03-05AE	●	●	5	10	9	100	24	-	11	2.5	15°	0.2	No	Fig.1	SB-1635TR	FT-6			
	S10H-SCLC%03-06AE	●	●	6				28		13	3	13°								
	S10H-SCLC%04-07AE	●	●	7				32		15	3.5	11°								
	S10H-SCLC%04-08AE	●	●	8				37		15	4	11°								
	A08X-SCLC%06-10AE	●	●	10	8	7	120	16	20	17	5	14°	0.4	Yes	Fig.2	SB-2545TR	FT-8			
	A10L-SCLC%06-12AE	●	●	12	10	9	140	20	25	21	6	12°								
	A12M-SCLC%06-14AE	●	●	14	12	11	150	24	30	25	7	10°								
	A16Q-SCLC%09-18AE	●	●	18	16	15	180	30	34	31	9	8°								
A20R-SCLC%09-22AE	●	●	22	20	19	200	36	49	37	11	8°									
A25S-SCLC%09-27AE	●	●	27	25	24	250	46	55	46	13.5	6°									
S08X-SCLC%06-10A	●	●	10	8	7	120	16	20	17	5	14°	0.4				No		Fig.2	SB-2545TR	FT-6
S10L-SCLC%06-12A	●	●	12	10	9	140	20	25	21	6	12°									
S12M-SCLC%06-14A	●	●	14	12	11	150	24	30	25	7	10°									
S16Q-SCLC%09-18A	●	●	18	16	15	180	30	34	31	9	10°									
S20R-SCLC%09-22A	●	●	22	20	19	200	36	49	37	11	8°									
S25S-SCLC%09-27A	●	●	27	25	24	250	46	55	46	13.5	6°									
C04G-SCLC%03-05A	●	●	5	4	3.8	90	9	-	8	2.5	15°	0.2	No	Fig.2	SB-1635TR	FT-6				
C05H-SCLC%03-06A	●	●	6	5	4.4	100	11		11	3	13°									
C06J-SCLC%04-07A	●	●	7	6	5.4	110	12		12	3.5	13°									
C07K-SCLC%04-08A	●	●	8	7	6.4	125	13		13	4	11°									
E08L-SCLC%06-10A	●	●	10	8	7	140	16	15	15	5	14°	0.4	Yes	Fig.2	SB2545TR	FT-8				
E08L-SCLC%06-10A-2/3	●	●				90														
E10N-SCLC%06-12A	●	●	12	10	9	160	20	19	19	6	12°									
E10N-SCLC%06-12A-2/3	●	●	105																	
E12Q-SCLC%06-14A	●	●	14	12	11	180	23	22	22	7	10°									
E12Q-SCLC%06-14A-2/3	●	●				120														
E16X-SCLC%09-18A	●	●	18	16	15	220	28	27	27	9	10°									
E16X-SCLC%09-18A-2/3	●	●				145														
E20S-SCLC%09-22A	●	●	22	20	19	250	32	31	31	11	8°				SB-4065TR		FT-15			
E20S-SCLC%09-22A-2/3	●	●				165														
E25T-SCLC%09-27A	●	●	27	25	24	300	38	37	37	13.5	6°									
E25T-SCLC%09-27A-2/3	●	●				200														

● Applicable Inserts

Toolholder	Applicable Inserts
...SCLC%03-...	CC ○ ○ 0301
...SCLC%04-...	CC ○ ○ 0401
...SCLC%06-...	CC ○ ○ 0602
...SCLC%09-...	CC ○ ○ 09T3

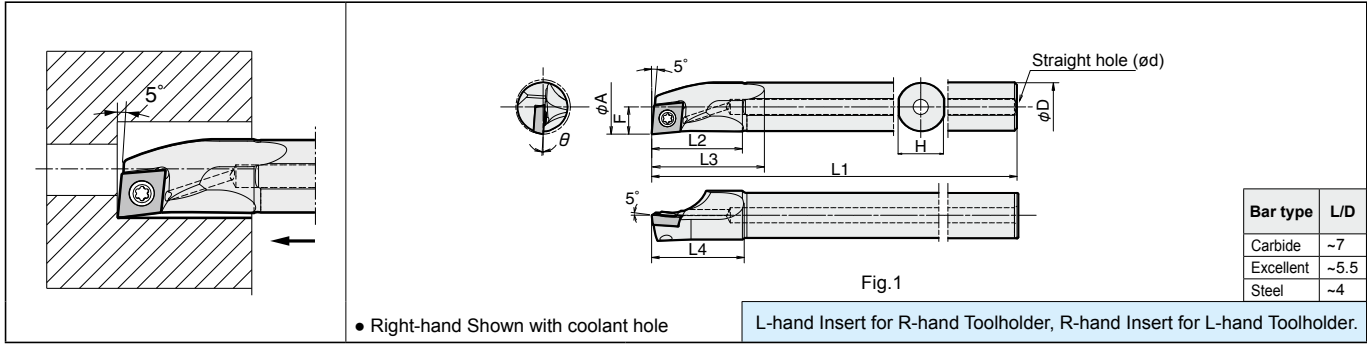

● Toolholder Dimensions

Description	Stock		Min. Bore Dia.	Dimension (mm)							θ	Standard Corner-R (rε)	Coolant Hole	Drawing	Spare Parts		
	R	L		φA	φD	H	L1	L2	L3	L4					F	Clamp Screw	Wrench
		●	●														
Excellent Bar	A10L-SCLP ^φ /L08-12AE	●	●	12	10	9	140	20	25	20	6	5°	0.4	Yes	Fig.1	SB-3060TR	FT-10
	A12M-SCLP ^φ /L08-14AE	●	●	14	12	11	150	24	29	24	7	4°					
	A12M-SCLP ^φ /L09-16AE	●	●	16													
	A16Q-SCLP ^φ /L09-18AE	●	●	18	16	15	180	30	37	30	9	3.5°					
	A20R-SCLP ^φ /L09-22AE	●	●	22	20	19	200	36	47	37	11	2°					
	A25S-SCLP ^φ /L09-27AE	●	●	27	25	24	250	46	55	46	13.5	0°					
Steel	S10L-SCLP ^φ /L08-12A	●	●	12	10	9	140	20	25	20	6	5°	0.4	No	Fig.1	SB-3060TR	FT-10
	S12M-SCLP ^φ /L08-14A	●	●	14	12	11	150	24	29	24	7	4°					
	S12M-SCLP ^φ /L09-16A	●	●	16													
	S16Q-SCLP ^φ /L09-18A	●	●	18	16	15	180	30	37	30	9	3.5°					
	S20R-SCLP ^φ /L09-22A	●	●	22	20	19	200	36	47	37	11	2°					
	S25S-SCLP ^φ /L09-27A	●	●	27	25	24	250	46	55	46	13.5	0°					
Carbide	E10N-SCLP ^φ /L08-12A	●	●	12	10	9	160	20	19	19	6	5°	0.4	Yes	Fig.1	SB-3060TR	FT-10
	E10N-SCLP ^φ /L08-12A-2 / 3	●					105										
	E10N-SCLP ^φ /L08-12A-1 / 2	●					80										
	E12Q-SCLP ^φ /L08-14A	●	●				180										
	E12Q-SCLP ^φ /L08-14A-2 / 3	●		120	23	22	22	7	4°								
	E12Q-SCLP ^φ /L08-14A-1 / 2	●		90													
	E16X-SCLP ^φ /L09-18A	●	●	18	16	15	220	28	27	27	9	3.5°					
	E16X-SCLP ^φ /L09-18A-2 / 3	●					145										
	E16X-SCLP ^φ /L09-18A-1 / 2	●					110										
	E20S-SCLP ^φ /L09-22A	●	●				250										
	E20S-SCLP ^φ /L09-22A-2 / 3	●		22	20	19	165	32	31	31	11	2°					
	E20S-SCLP ^φ /L09-22A-1 / 2	●					125										
	E25T-SCLP ^φ /L09-27A	●	●				300										
	E25T-SCLP ^φ /L09-27A-2 / 3	●		27	25	24	200	38	37	37	13.5	0°					
	●		200														

● Applicable Inserts

Toolholder	Applicable Inserts
...SCLP ^φ /L08-...	CP ○○ 0802
...SCLP ^φ /L09-...	CP ○○ 0903

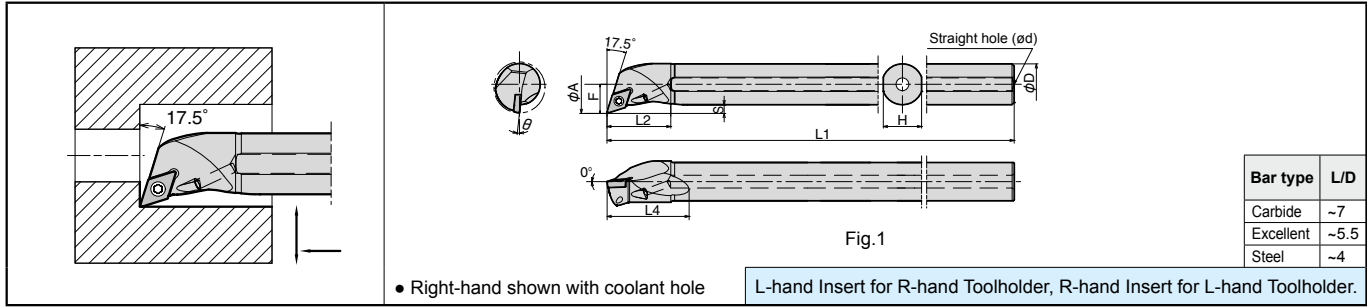

● Toolholder Dimensions

Description	Stock		Min. Bore Dia.	Dimension (mm)										θ	Standard Corner-R (R)	Coolant Hole	Drawing	Spare Parts		
	R	L		øA	øD	H	L1	L2	L3	L4	F	S	Clamp Screw					Wrench		
Excellent Bar	A10L-SDQC%07-13AE	●	●	13	10	9	140	19				21	7.5	2.1	10°	0.4	Yes	Fig.1	SB-2560TR	FT-8
	A12M-SDQC%07-16AE	●	●	16	12	11	150	22				25	9.25	2.6	8°					
	A16Q-SDQC%07-20AE	●	●	20	16	15	180	25	-			32	11.3	2.6	6°					
	A20R-SDQC%11-25AE	●	●	25	20	19	200	31				37	14.4	3.7	5°					
A25S-SDQC%11-30AE	●	●	30	25	24	250	38				45	16.9	3.7	4°						
Steel	S10L-SDQC%07-13A	●	●	13	10	9	140	19				21	7.5	2.1	10°	0.4	No	Fig.1	SB-2560TR	FT-8
	S12M-SDQC%07-16A	●	●	16	12	11	150	22				25	9.25	2.6	8°					
	S16Q-SDQC%07-20A	●	●	20	16	15	180	25	-			32	11.3	2.6	6°					
	S20R-SDQC%11-25A	●	●	25	20	19	200	31				37	14.4	3.7	5°					
	S25S-SDQC%11-30A	●	●	30	25	24	250	38				45	16.9	3.7	4°					
Carbide	E10N-SDQC%07-13A	●	●	13	10	9	160	20	-	19	7.5	2.1	10°	0.4	Yes	Fig.1	SB-2560TR	FT-8		
	E10N-SDQC%07-13A-2 / 3	●	●				105													
	E12Q-SDQC%07-16A	●	●	16	12	11	180	23	-	22	9.25	2.6	8°							
	E12Q-SDQC%07-16A-2 / 3	●	●				120													
	E16X-SDQC%07-20A	●	●	20	16	15	220	28	-	27	11.3	2.6	6°							
	E16X-SDQC%07-20A-2 / 3	●	●				145													
	E20S-SDQC%11-25A	●	●	25	20	19	250	32	-	31	14.4	3.7	5°							
	E20S-SDQC%11-25A-2 / 3	●	●				165													
	E25T-SDQC%11-30A	●	●	30	25	24	300	38	-	37	16.9	3.7	4°							
E25T-SDQC%11-30A-2 / 3	●	●	200																	

● Applicable Inserts

Toolholder	Applicable Inserts
...-SDQC%07-...	DC ○○ 0702
...-SDQC%11-...	DC ○○ 11T3

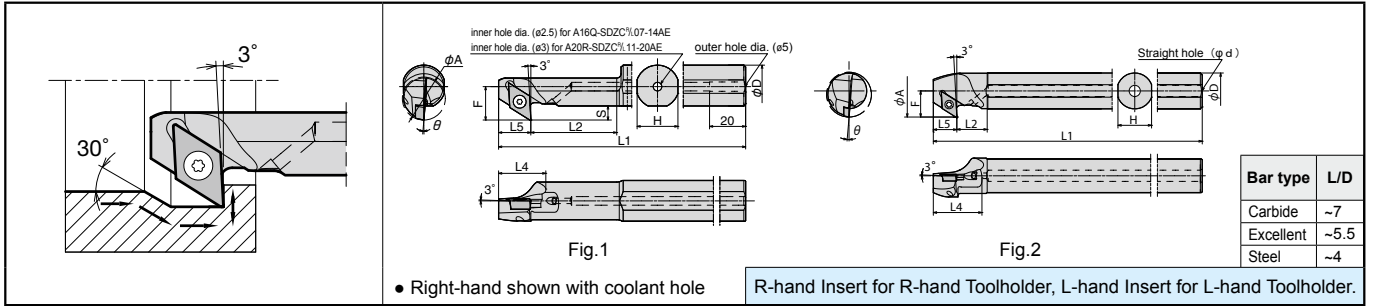

● Toolholder Dimensions

Description	Stock		Min. Bore Dia.	Dimension (mm)								θ	Standard Corner-R (R)	Coolant Hole	Drawing	Spare Parts		
	R	L		øA	øD	H	L1	L2	L4	L5	F					S	Clamp Screw	Wrench
Excellent Bar	A16Q-SDZC%07-14AE	●	●	14	16	15	180	30	17	10	10.8	4.4	5°	0.4	Yes	Fig.1	SB-2545TR	FT-8
	A20R-SDZC%11-20AE	●	●	20	20	19	200	40	24	15	15.6	6.1					SB-4065TR	FT-15
	A10L-SDZC%07-14AE	●	●	14	10	9	140	14	16	9.5	8.7	3.3	5°	0.4	Yes	Fig.2	SB-2545TR	FT-8
	A12M-SDZC%07-16AE	●	●	16	12	11	150	14	20	10.5	9.7	3.3					SB-2560TR	
	A16Q-SDZC%07-20AE	●	●	20	16	15	180	14	22	10.5	11.7	3.3	5°	0.4	Yes	Fig.2	SB-4065TR	FT-15
	A16Q-SDZC%11-23AE	●	●	23	16	15	180	15	22	15	14.5	6.1					SB-4065TR	FT-15
	A20R-SDZC%11-27AE	●	●	27	20	19	200	15	25	15	16.5	6.1	5°	0.4	No	Fig.1	SB-2545TR	FT-8
	A25S-SDZC%11-32AE	●	●	32	25	24	250	15	26	15	19	6.1					SB-4065TR	FT-15
Steel	S16Q-SDZC%07-14A	●	●	14	16	15	180	30	17	10	10.8	4.4	5°	0.4	No	Fig.1	SB-2545TR	FT-8
	S20R-SDZC%11-20A	●	●	20	20	19	200	40	24	15	15.6	6.1					SB-4065TR	FT-15
	S10L-SDZC%07-14A	●	●	14	10	9	140	14	16	9.5	8.7	3.3	5°	0.4	No	Fig.2	SB-2545TR	FT-8
	S12M-SDZC%07-16A	●	●	16	12	11	150	14	20	10.5	9.7	3.3					SB-2560TR	
	S16Q-SDZC%07-20A	●	●	20	16	15	180	14	22	10.5	11.7	3.3	5°	0.4	No	Fig.2	SB-4065TR	FT-15
	S16Q-SDZC%11-23A	●	●	23	16	15	180	15	22	15	14.5	6.1					SB-4065TR	FT-15
	S20R-SDZC%11-27A	●	●	27	20	19	200	15	25	15	16.5	6.1	5°	0.4	No	Fig.2	SB-2545TR	FT-8
	S25S-SDZC%11-32A	●	●	32	25	24	250	15	26	15	19	6.1					SB-4065TR	FT-15
Carbide	E10N-SDZC%07-14A	●		14	10	9	160	10.5	16	9.5	8.7	3.3	5°	0.4	Yes	Fig.2	SB-2545TR	FT-8
	E12Q-SDZC%07-16A	●		16	12	11	180	12.5	20	10.5	9.7	3.3					SB-2560TR	
	E16X-SDZC%07-20A	●		20	16	15	220	17.5	22	10.5	11.7	3.3	5°	0.4	Yes	Fig.2	SB-2545TR	FT-8
	E16X-SDZC%11-23A	●		23	16	15	220	17	22	15	14.5	6.1					SB-4065TR	FT-15
	E20S-SDZC%11-27A	●		27	20	19	250	23	25	15	16.5	6.1						

● Applicable Inserts

Toolholder	Applicable Inserts
...-SDZC%07-...	DC ○○ 0702
...-SDZC%11-...	DC ○○ 11T3

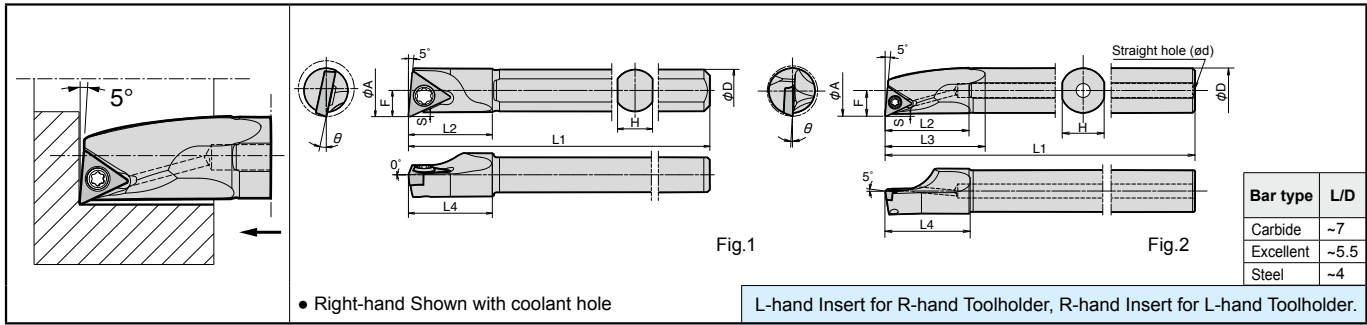

● Toolholder Dimensions

Description	Stock		Min. Bore Dia.	Dimension (mm)										θ	Standard Corner-R (rε)	Coolant Hole	Drawing	Spare Parts	
	R	L		∅A	∅D	H	L1	L2	L3	L4	F	S	Clamp Screw					Wrench	
Excellent Bar	●	●	8	6	5	100	12	-	12	3.8	0.5	12°	0.4	Yes	Fig.2	SB-2035TR	FT-6		
	●	●	10	8	7	120	16	22	16	5	0.5	10°						SB-2545TR	FT-8
	●	●	12	10	9	140	20	25	20	6.2	0.9	8°							
	●	●	14	12	11	150	24	30	24	7.2	0.8	7°						SB-3060TR	FT-10
	●	●	18	16	15	180	30	36	30	9.2	3.5°								
	●	●	22	20	19	200	36	46	37	11.2	0.7	2°							
	●	●	27	25	24	250	46	55	46	13.7	0°	SB-4065TR						FT-15	
Steel	●	●	8	6	5	100	12	-	12	3.8	0.5	12°	0.4	No	Fig.1	SB-2035TR	FT-6		
	●	●	10	8	7	120	16	22	16	5	0.5	10°						SB-2545TR	FT-8
	●	●	12	10	9	140	20	25	20	6.2	0.9	8°							
	●	●	14	12	11	150	24	30	24	7.2	0.8	7°						SB-3060TR	FT-10
	●	●	18	16	15	180	30	36	30	9.2	3.5°								
	●	●	22	20	19	200	36	46	37	11.2	0.7	2°							
	●	●	27	25	24	250	46	55	46	13.7	0°	SB-4065TR						FT-15	
	Carbide	●	●	8	6	5.4	110	12	-	12	3.8	0.5						12°	0.4
●		●	10	8	7	140	16	15	15	5	0.5	10°							
●		●	12	10	9	160	20	19	19	6.2	0.9	8°							
●		●				105													
●		●				80													
●		●	14	12	11	160	23	22	22	7.2	0.8	7°							
●		●				105													
●		●				80													
●		●	18	16	15	180	28	27	27	9.2	3.5°								
●		●				145													
●		●				110													
●		●	22	20	19	220	32	31	31	11.2	0.7	2°							
●		●				250													
●		●				165													
●		●	27	25	24	125	38	37	37	13.7	0°								
●	●	300																	
●	●	200																	
●	●	SB-4065TR	FT-15																

● Applicable Inserts

Toolholder	Applicable Inserts
...-STLB%06-...	TB ○○ 0601
...-STLP%09-...	TP ○○ 0902
...-STLP%11-...	TP ○○ 1103
...-STLP%16-...	TP ○○ 1603

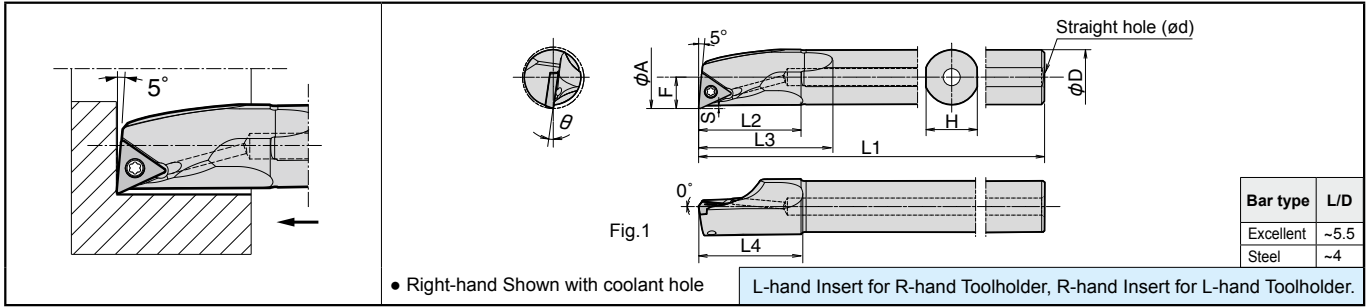

● Toolholder Dimensions

Description	Stock		Min. Bore Dia. øA	Dimension (mm)									θ	Standard Corner-R (r)	Coolant Hole	Drawing	Spare Parts	
	R	L		øD	H	L1	L2	L3	L4	F	S	Clamp Screw					Wrench	
																	0.4	Yes
Excellent Bar	A08X-STLC [®] /09-10AE	●	●	10	8	7	120	16	22	16	5	0.5	14°	0.4	Yes	Fig.1	SB-2250TR	FT-7
	A10L-STLC [®] /09-12AE	●	●	12	10	9	140	20	26	20	6.2	0.9	12°					
	A10L-STLC [®] /11-12AE	●	●	12	10	9	140	20	26	20	6.2	0.9	12°					
	A12M-STLC [®] /11-14AE	●	●	14	12	11	150	24	30	25	7.2	0.7	10°					
	A16Q-STLC [®] /11-18AE	●	●	18	16	15	180	30	39	31	9.2	0.7	8°					
A20R-STLC [®] /11-22AE	●	●	22	20	19	200	36	44	36	11.2	0.7	6°						
Steel	S08X-STLC [®] /09-10A	●	●	10	8	7	120	16	22	16	5	0.5	14°	0.4	No	Fig.1	SB-2250TR	FT-7
	S10L-STLC [®] /09-12A	●	●	12	10	9	140	20	26	20	6.2	0.9	12°					
	S10L-STLC [®] /11-12A	●	●	12	10	9	140	20	26	20	6.2	0.9	12°					
	S12M-STLC [®] /11-14A	●	●	14	12	11	150	24	30	25	7.2	0.7	10°					
	S16Q-STLC [®] /11-18A	●	●	18	16	15	180	30	39	31	9.2	0.7	8°					
	S20R-STLC [®] /11-22A	●	●	22	20	19	200	36	44	36	11.2	0.7	6°					

● Applicable Inserts

Toolholder	Applicable Inserts
...-STLC [®] /09-...	TC ○○ 0902
...-STLC [®] /11-...	TC ○○ 1102

SVJP(C)(B)

Screw Clamp

Fig. 1 Fig. 2

* No shim for SVJP(C) 08 type / SVJB 11 type.

- Right-hand shown with coolant hole
- L-hand Insert for R-hand Toolholder, R-hand Insert for L-hand Toolholder.

Bar type	L/D
Excellent	~5.5
Steel	~4

SVPC(B)

Screw Clamp

Fig. 3 Fig. 4

* No shim for SVPC 08 type / SVPB 11 type.

- Right-hand shown with coolant hole
- L-hand Insert for R-hand Toolholder, R-hand Insert for L-hand Toolholder.

Bar type	L/D
Carbide	~7
Excellent	~5.5
Steel	~4

Toolholder Dimensions

Description	Stock		Min. Bore Dia.	Dimension (mm)								θ	Standard Corner-R (r)	Coolant Hole	Drawing	Spare Parts		
	R	L		φA	φD	H	L1	L2	L3	L4	F					S	Clamp Screw	Wrench
Excellent Bar	●	●	16	12	11	150	26	33	21	2	-	5°	0.2	Yes	Fig.1	SB-2050TR	FT-6	
	●	●	16	12	11	150	26	33	20	2	-	5°				SB-2570TR	FT-8	
	●	●	20	16	15	180	36	43	22	2	-	5°				Fig.2	SB-40125TRN	FT-15
	●	●	25	20	19	200	37.5	48	30	2	-	5°						
	●	●	30	25	24	250	45	58	33	3.5	-	5°						
	●	●	40	32	31	250	60	74	45	3.5	-	8°						
●	●	50	40	39	300	75	91	49	4.5	-	7°	0.2	No	Fig.1	SB-2050TR	FT-6		
●	●	16	12	11	150	26	33	21	2	-	5°				SB-2570TR	FT-8		
●	●	20	16	15	180	36	43	22	2	-	5°				Fig.2	SB-40125TRN	FT-15	
●	●	25	20	19	200	37.5	48	30	2	-	5°							
●	●	30	25	24	250	45	58	33	3.5	-	5°							
●	●	40	32	31	250	60	74	45	3.5	-	8°							
●	●	50	40	39	300	75	91	49	4.5	-	7°	0.4	Yes	Fig.3	SB-2050TR	FT-6		
●	●	18	12	11	150	29	-	26	11	4.5	8°				SB-2570TR	FT-8		
●	●	22	16	15	180	35	-	33	13.5	5	5°				Fig.4	SB-40125TRN	FT-15	
●	●	26	20	19	200	41	-	39	15.5	5	5°							
●	●	31	25	24	250	51	-	49	18	5	13°							
●	●	40	32	31	250	54	-	53	23	6.5	9°							
Steel	●	●	14	10	9	140	24	-	21	8.5	3	8°	0.4	No	Fig.3	SB-2050TR	FT-6	
	●	●	18	12	11	150	29	-	26	11	4.5	8°				SB-2570TR	FT-8	
	●	●	22	16	15	180	35	-	33	13.5	5	5°				Fig.4	SB-40125TRN	FT-15
	●	●	26	20	19	200	41	-	39	15.5	5	5°						
	●	●	31	25	24	250	51	-	49	18	5	13°						
	●	●	40	32	31	250	54	-	53	23	6.5	9°						
Carbide	●	●	14	10	9	160	20	-	18.5	8.5	3	8°	0.4	Yes	Fig.3	SB-2050TR	FT-6	
	●	●	18	12	11	180	23	-	22	11	4.5	8°				SB-2570TR	FT-8	
	●	●	22	16	15	220	28	-	27	13.5	5	5°				Fig.4	SB-40125TRN	FT-15
	●	●	26	20	19	250	32	-	31	15.5	5	5°						
	●	●	31	25	24	300	38	-	37	18	5	13°						
	●	●	31	25	24	300	38	-	37	18	5	13°						

Applicable Inserts

Toolholder	Applicable Inserts
...-SVJP 08-...	VP ○○ 0802 VC ○○ 0802
...-SVJC 08-...	VC ○○ 0802
...-SVJB 11-...	VB ○○ 1103
...-SVPB 11-...	VB ○○ 1103
...-SVJB 16-...	VB ○○ 1604
...-SVPB 16-...	VB ○○ 1604

Spare Parts

Description	Spare Parts		
	Shim	Shim Screw	Wrench (for Shim Screw)
○32S-SVJB 16-40A○ ○40T-SVJB 16-50A○ ○25S-SVPB 16-31A○ ○32S-SVPB 16-40A○	SVN-32N	SS-4N	LW-4

Application of SVJ

1. Application Range

●●●● SVJB%16-50○
 ●●●● SVJB%16-40○
 ●●●● SVJB%11-30○
 ●●●● SVJB%11-25○
 ●●●● SVJC%08-20○
 ●●●● SVJC%08-16○
 ●●●● SVJP%08-16○
 ○○ VB 1604 type
 ○○ VB 1103 type
 ○○ VC (P) 0802 type

2. Machining method

Case with No Existing Hole	Finishing
<p>(Note) f shall be under 0.05mm/rev at internal facing.</p>	<p>Spherical Machining</p> <p>Internal Facing</p> <p>Machining Process ① Finish the internal face first. ② Next, finish the internal diameter.</p>
<p>Case with Drilled Hole</p> <p>(Note) f shall be under 0.05mm/rev at internal facing.</p>	<p>Internal Facing</p> <p>Machining Process ① Finish the internal face first. ② Next, finish the internal diameter.</p>

3. Caution

When machining past the center of the workpiece, insert breakage may occur.

Fix the insert edge at the center of the workpiece.

Adjust the machining program of radius smaller by Corner-R (r_ϵ) value.

Machining of this kind is available, but the oblique part may be scratched by chips.

Poor finish

For internal profiling, a_p should be less than the value of Corner-R (r_ϵ).

[Burs may occur, if a_p is bigger than Corner-R (r_ϵ).]

SVUC(B)

Screw Clamp

inner hole dia. (ø3) for A12M-SVUC% 08-16AE
 inner hole dia. (ø3) for A16Q-SVUB% 11-20AE
 inner hole dia. (ø3) for A20R-SVUB% 11-25AE
 Straight hole dia. (ø5) for A32S-SVUB% 16-40AE

Bar type	L/D
Carbide	~7
Excellent	~5.5
Steel	~4

• Right-hand shown with coolant hole

L-hand Insert for R-hand Toolholder, R-hand Insert for L-hand Toolholder.

SVZC(B)

Screw Clamp

inner hole dia. (ø3) for A12M-SVZC% 08-16AE
 inner hole dia. (ø3) for A16Q-SVZB% 11-20AE
 inner hole dia. (ø3) for A20R-SVZB% 11-25AE
 Straight hole dia. (ø5) for A32S-SVZB% 16-40AE

Bar type	L/D
Excellent	~5.5
Steel	~4

• Right-hand shown with coolant hole

* No shim for SVZC% 08 type / SVZB% 11 type.

R-hand Insert for R-hand Toolholder, L-hand Insert for L-hand Toolholder.

Toolholder Dimensions

Description	Stock		Min. Bore Dia. øA	Dimension (mm)								θ	Standard Corner-R (rc)	Coolant Hole	Drawing	Spare Parts		
	R	L		øD	H	L1	L2	L4	L5	F	S					Clamp Screw	Wrench	
Excellent Bar	A12M-SVUC% 08-16AE	●	●	16	12	11	150	25.5	23	-	11.5	5.5	8°	0.4	Yes	Fig.1	SB-2050TR	FT-6
	A16Q-SVUB% 11-20AE	●	●	20	16	15	180	32.5	27	-	16	8	8°				SB-2570TR	FT-8
	A20R-SVUB% 11-25AE	●	●	25	20	19	200	40.5	31	-	18	8	7°			SB-40125TRN	FT-15	
	A25S-SVUB% 16-34AE	●	●	34	25	24	250	40	37	-	20.5	8.5	13°					
	A32S-SVUB% 16-40AE	●	●	40	32	31	250	84	47	-	28	12	9°					
Steel	S12M-SVUC% 08-16A	●	●	16	12	11	150	25.5	23	-	11.5	5.5	8°	0.4	No	Fig.1	SB-2050TR	FT-6
	S16Q-SVUB% 11-20A	●	●	20	16	15	180	32.5	27	-	16	8	8°				SB-2570TR	FT-8
	S20R-SVUB% 11-25A	●	●	25	20	19	200	40.5	31	-	18	8	7°			SB-40125TRN	FT-15	
	S25S-SVUB% 16-34A	●	●	34	25	24	250	40	37	-	20.5	8.5	13°					
	S32S-SVUB% 16-40A	●	●	40	32	31	250	84	47	-	28	12	9°					
Carbide	E12Q-SVUC% 08-18A	●		18	12	11	180	23	22	-	11.5	5.5	8°	0.4	Yes	Fig.2	SB-2050TR	FT-6
	E16X-SVUB% 11-25A	●		25	16	15	220	28	27	-	16	8	8°				SB-2570TR	FT-8
	E20S-SVUB% 11-29A	●		29	20	19	250	32	30	-	18	8	7°			SB-40125TRN	FT-15	
	E25T-SVUB% 16-34A	●		34	25	24	300	38	37	-	21	8.5	13°					
		●																
Excellent Bar	A12M-SVZC% 08-16AE	●	●	16	12	11	150	25.5	14	7.5	11.5	5.5	8°	0.4	Yes	Fig.3	SB-2050TR	FT-6
	A16Q-SVZB% 11-20AE	●	●	20	16	15	180	32.5	20	10	16	8	8°				SB-2570TR	FT-8
	A20R-SVZB% 11-25AE	●	●	25	20	19	200	40.5	23	10	18	8	7°			SB-40125TRN	FT-15	
	A25S-SVZB% 16-34AE	●	●	34	25	24	250	30	34	17.5	20.5	8.5	13°					
	A32S-SVZB% 16-40AE	●	●	40	32	31	250	72.5	36	17.5	28	12	9°					
Steel	S12M-SVZC% 08-16A	●	●	16	12	11	150	25.5	14	7.5	11.5	5.5	8°	0.4	No	Fig.3	SB-2050TR	FT-6
	S16Q-SVZB% 11-20A	●	●	20	16	15	180	32.5	20	10	16	8	8°				SB-2570TR	FT-8
	S20R-SVZB% 11-25A	●	●	25	20	19	200	40.5	23	10	18	8	7°			SB-40125TRN	FT-15	
	S25S-SVZB% 16-34A	●	●	34	25	24	250	30	34	17.5	20.5	8.5	13°					
	S32S-SVZB% 16-40A	●	●	40	32	31	250	72.5	36	17.5	28	12	9°					

Applicable Inserts

Toolholder	Applicable Inserts
...-SVUC% 08-...	VC ○○ 0802
...-SVZC% 08-...	VC ○○ 0802
...-SVUB% 11-...	VB ○○ 1103
...-SVZB% 11-...	VB ○○ 1103
...-SVUB% 16-...	VB ○○ 1604
...-SVZB% 16-...	VB ○○ 1604

Spare Parts

Description	Spare Parts		
	Shim	Shim Screw	Wrench (for Shim Screw)
A25S-SVUB% 16-34AE	SVN-32N	SS-4N	LW-4
A32S-SVUB% 16-40AE			
A25S-SVZB% 16-34AE			
A32S-SVZB% 16-40AE			

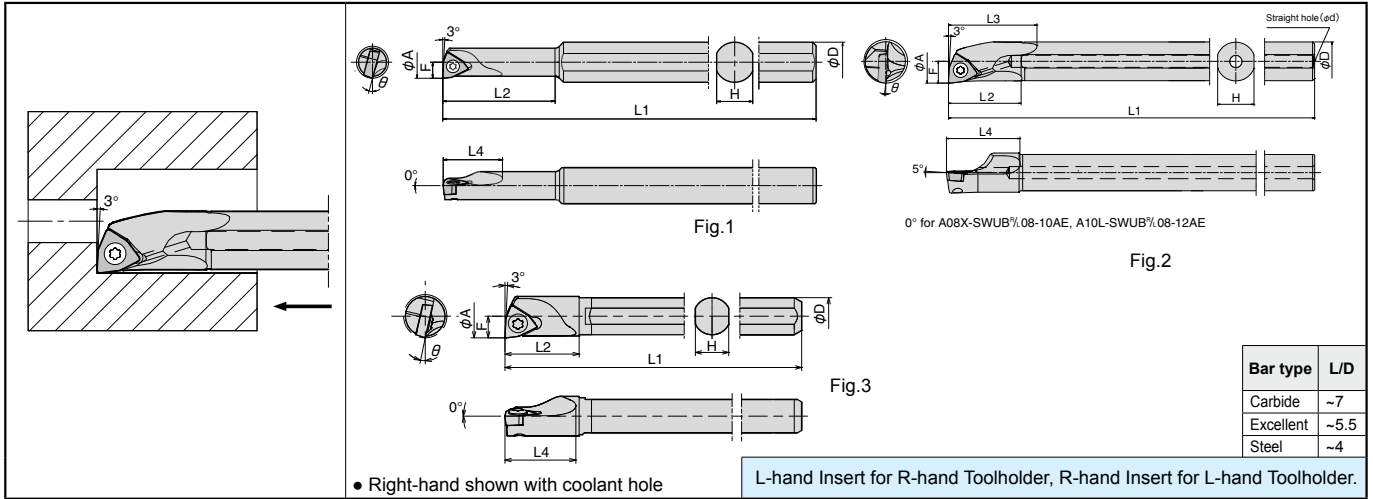

● Toolholder Dimensions

Description	Stock		Min. Bore Dia.	Dimension (mm)								θ	Standard Corner-R (rε)	Coolant Hole	Drawing	Spare Parts				
	R	L		ϕA	ϕD	H	L1	L2	L3	L4	F					S	Clamp Screw	Wrench		
Excellent Bar	●	●	6	10	9	100	21	-	13	3	-	15°	0.2	No	Fig.1	SB-2035TR	FT-6			
	●	●	7	10	9	100	24.5	-	15	3.5	-	13°				SB-2050TR				
	●	●	8	10	9	100	28	-	15	4	-	15°		0.4	Yes	Fig.2	SB-2545TR	FT-8		
	●	●	10	8	7	120	16	21	16	5	-	13°					SB-4065TR		FT-15	
	●	●	12	10	9	140	20	25	20	6	-	10°		0.8	Yes	Fig.2	SB-2545TR	FT-8		
	●	●	14	12	11	150	24	30	24	7	-	4°					SB-4065TR		FT-15	
	●	●	18	16	15	180	30	37	30	9	-	1°		0.8	Yes	Fig.2	SB-2545TR	FT-8		
	●	●	16	16	15	180	30	37	30	9	-	3.5°					SB-4065TR		FT-15	
●	●	22	20	19	200	36	46	37	11	-	2°									
Steel	●	●	6	10	9	100	21	-	13	3	-	15°	0.2	No	Fig.1	SB-2035TR	FT-6			
	●	●	7	10	9	100	25	-	15	3.5	-	13°				SB-2050TR				
	●	●	8	10	9	100	28	-	15	4	-	15°				0.4	Yes	Fig.2	SB-2545TR	FT-8
	●	●	10	8	7	120	16	21	16	5	-	13°							SB-4065TR	
	●	●	12	10	9	140	20	25	20	6	-	10°				0.8	Yes	Fig.2	SB-2545TR	FT-8
	●	●	14	12	11	150	24	30	24	7	-	4°							SB-4065TR	
	●	●	18	16	15	180	30	37	30	9	-	1°								
	●	●	16	16	15	180	30	37	30	9	-	3.5°								
	●	●	22	20	19	200	36	46	37	11	-	2°								
	Carbide	●	●	6	5	4.4	100	11	-	11	3	-				13°	0.2	No	Fig.3	SB-2035TR
●		●	7	6	5.4	110	12	-	12	3.5	-	13°	SB-2050TR							
●		●	8	7	6.4	125	13	-	13	4	-	13°	0.4	Yes	Fig.2	SB-2545TR				FT-8
●		●	10	8	7	140	16	15	15	5	-	13°				SB-4065TR				
●		●	12	10	9	160	20	19	19	6	-	10°	0.8	Yes	Fig.2	SB-2545TR				FT-8
●		●	14	12	11	180	23	22	22	7	-	4°				SB-4065TR				
●		●	18	16	15	220	28	27	27	9	-	1°								
●		●	16	16	15	220	27	27	27	9	-	3.5°								
●		●	14	12	11	120	23	22	22	7	-	4°	0.8	Yes	Fig.2	SB-2545TR				FT-8
●		●	18	16	15	110	28	27	27	9	-	1°				SB-4065TR				
●		●	16	16	15	220	27	27	27	9	-	3.5°								
●		●	14	12	11	120	23	22	22	7	-	4°	0.8	Yes	Fig.2	SB-2545TR				FT-8
●		●	18	16	15	110	28	27	27	9	-	1°				SB-4065TR				
●		●	16	16	15	220	27	27	27	9	-	3.5°								
●		●	14	12	11	120	23	22	22	7	-	4°	0.8	Yes	Fig.2	SB-2545TR				FT-8
●		●	18	16	15	110	28	27	27	9	-	1°				SB-4065TR				
●		●	16	16	15	220	27	27	27	9	-	3.5°								
●		●	14	12	11	120	23	22	22	7	-	4°	0.8	Yes	Fig.2	SB-2545TR				FT-8
●		●	18	16	15	110	28	27	27	9	-	1°				SB-4065TR				
●		●	16	16	15	220	27	27	27	9	-	3.5°								
●	●	14	12	11	120	23	22	22	7	-	4°	0.8	Yes	Fig.2	SB-2545TR	FT-8				
●	●	18	16	15	110	28	27	27	9	-	1°				SB-4065TR		FT-15			
●	●	16	16	15	220	27	27	27	9	-	3.5°									
●	●	14	12	11	120	23	22	22	7	-	4°	0.8	Yes	Fig.2	SB-2545TR	FT-8				
●	●	18	16	15	110	28	27	27	9	-	1°				SB-4065TR		FT-15			
●	●	16	16	15	220	27	27	27	9	-	3.5°									
●	●	14	12	11	120	23	22	22	7	-	4°	0.8	Yes	Fig.2	SB-2545TR	FT-8				
●	●	18	16	15	110	28	27	27	9	-	1°				SB-4065TR		FT-15			
●	●	16	16	15	220	27	27	27	9	-	3.5°									
●	●	14	12	11	120	23	22	22	7	-	4°	0.8	Yes	Fig.2	SB-2545TR	FT-8				
●	●	18	16	15	110	28	27	27	9	-	1°				SB-4065TR		FT-15			
●	●	16	16	15	220	27	27	27	9	-	3.5°									
●	●	14	12	11	120	23	22	22	7	-	4°	0.8	Yes	Fig.2	SB-2545TR	FT-8				
●	●	18	16	15	110	28	27	27	9	-	1°				SB-4065TR		FT-15			
●	●	16	16	15	220	27	27	27	9	-	3.5°									
●	●	14	12	11	120	23	22	22	7	-	4°	0.8	Yes	Fig.2	SB-2545TR	FT-8				
●	●	18	16	15	110	28	27	27	9	-	1°				SB-4065TR		FT-15			
●	●	16	16	15	220	27	27	27	9	-	3.5°									
●	●	14	12	11	120	23	22	22	7	-	4°	0.8	Yes	Fig.2	SB-2545TR	FT-8				
●	●	18	16	15	110	28	27	27	9	-	1°				SB-4065TR		FT-15			
●	●	16	16	15	220	27	27	27	9	-	3.5°									
●	●	14	12	11	120	23	22	22	7	-	4°	0.8	Yes	Fig.2	SB-2545TR	FT-8				
●	●	18	16	15	110	28	27	27	9	-	1°				SB-4065TR		FT-15			
●	●	16	16	15	220	27	27	27	9	-	3.5°									
●	●	14	12	11	120	23	22	22	7	-	4°	0.8	Yes	Fig.2	SB-2545TR	FT-8				
●	●	18	16	15	110	28	27	27	9	-	1°				SB-4065TR		FT-15			
●	●	16	16	15	220	27	27	27	9	-	3.5°									
●	●	14	12	11	120	23	22	22	7	-	4°	0.8	Yes	Fig.2	SB-2545TR	FT-8				
●	●	18	16	15	110	28	27	27	9	-	1°				SB-4065TR		FT-15			
●	●	16	16	15	220	27	27	27	9	-	3.5°									
●	●	14	12	11	120	23	22	22	7	-	4°	0.8	Yes	Fig.2	SB-2545TR	FT-8				
●	●	18	16	15	110	28	27	27	9	-	1°				SB-4065TR		FT-15			
●	●	16	16	15	220	27	27	27	9	-	3.5°									
●	●	14	12	11	120	23	22	22	7	-	4°	0.8	Yes	Fig.2	SB-2545TR	FT-8				
●	●	18	16	15	110	28	27	27	9	-	1°				SB-4065TR		FT-15			
●	●	16	16	15	220	27	27	27	9	-	3.5°									
●	●	14	12	11	120	23	22	22	7	-	4°	0.8	Yes	Fig.2	SB-2545TR	FT-8				
●	●	18	16	15	110	28	27	27	9	-	1°				SB-4065TR		FT-15			
●	●	16	16	15	220	27	27	27	9	-	3.5°									
●	●	14	12	11	120	23	22	22	7	-	4°	0.8	Yes	Fig.2	SB-2545TR	FT-8				
●	●	18	16	15	110	28	27	27	9	-	1°				SB-4065TR		FT-15			
●	●	16	16	15	220	27	27	27	9	-	3.5°									
●	●	14	12	11	120	23	22	22	7	-	4°	0.8	Yes	Fig.2	SB-2545TR	FT-8				
●	●	18	16	15	110	28	27	27	9	-	1°				SB-4065TR		FT-15			
●	●	16	16	15	220	27	27	27	9	-	3.5°									
●	●	14	12	11	120	23	22	22	7	-	4°	0.8	Yes	Fig.2	SB-2545TR	FT-8				

■ **Toolholder Lineup**
Bohrstangen Ausführung
Gamme de porte-outils
Serie portautensile

Excellent Bar

With internal coolant hole provides better chip evacuation.

Die Innenkühlbohrung gewährleistet eine verbesserte Spanabfuhr.

Avec lubrification (arrosage central) garantit une meilleure évacuation des copeaux.

Con foro per la lubro-refrigerazione interna garantisce una migliore evacuazione del truciolo.

Steel Bar

Provides superior cost performance (without coolant hole).

Ermöglicht kosteneffizientes Arbeiten (ohne Kühlmittelbohrung).

Les barres acier sont très économiques (sans arrosage interne).

Per lavorazioni standard ha costi minori rispetto al barenno mod. Excellent (senza foro per la lubro-refrigerazione).

Carbide Bar

High rigidity toolholder for precision and longer overhang length.

Werkzeughalter mit hoher Steifigkeit für Präzise Bearbeitung und größerer Auskraglänge.

Porte-à- faux et précision accrues du fait de la grande rigidité du porte outil.

Barenno ad alta rigidità per lavorazioni di precisione a sbalzo.



Excellent Bar



Steel Bar

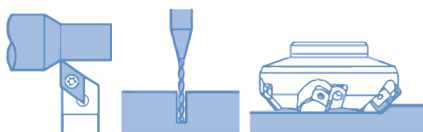

THIEME
CNC-Werkzeugtechnik

Erich THIEME GmbH
Königsfelderstraße 33 | 58256 Ennepetal
☎ 02333 | 9786-0 📠 02333 | 9786-49
www.thieme-werkzeuge.de
info@thieme-werkzeuge.de