

THIEME Zerspanen
Spannen
Messen

MagicDrill **DRA**

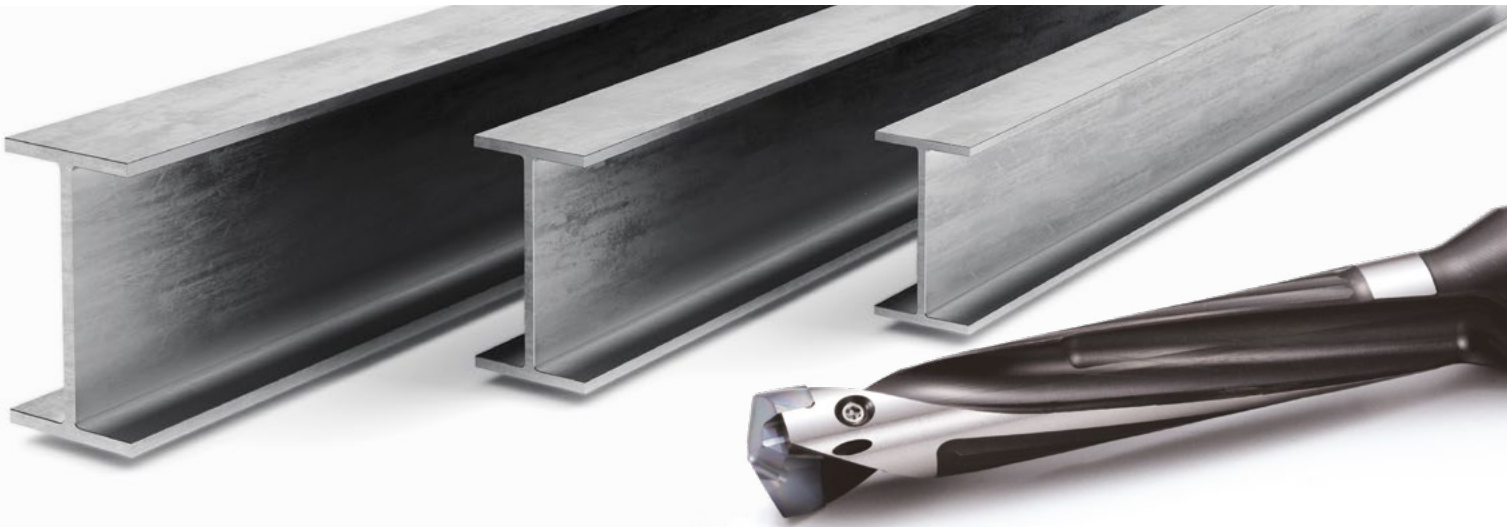

High efficient and reliable drilling in structural steel beam

Optimal web thickness limits deflection

Easy insert replacement

Insert sizes: DC = 7.94 mm - 33.00 mm

Toolholder L/D: 1.5D - 12D

1st choice
for general
machining
GM



For minimal
burr creation
FTP

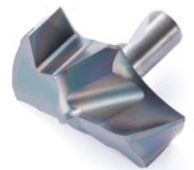

Best performance
in steel beam
FTP-H

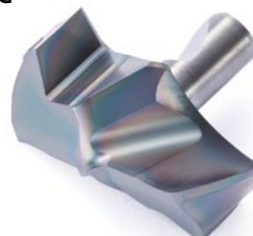

Full lineup

High efficient steel beam drilling

MagicDrill DRA

Excellent hole accuracy with a low cutting force design

Fine chip breaking and smooth deep hole cutting

New FTP-H insert available for best performance in steel beam drilling



1 Low cutting force design improves hole accuracy

Special chisel edge with S-curve reduces thrust force and controls vibration

Cutting edge image

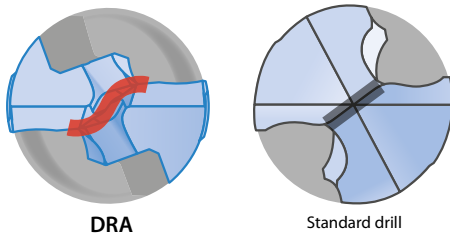

2 Optimal web thickness limits deflection

Improved hole accuracy by controlling drill deflection with a 20% thicker web compared with Competitor A

Web thickness comparison

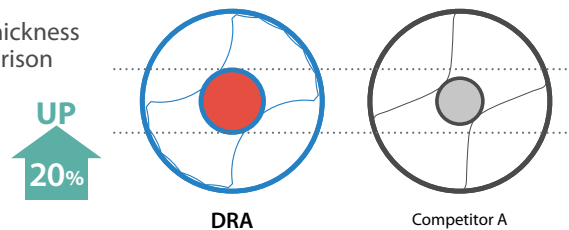

3 Optimized chip control

Optimized chip thinning for stable chip evacuation

Chip comparison (Internal evaluation)

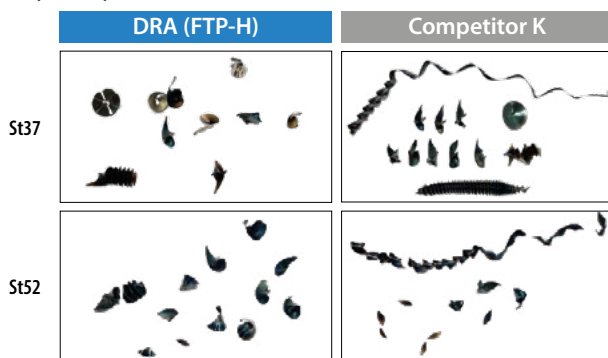

4 Excellent surface finish

Controlled chips reduce scratches on the hole wall

Hole quality comparison (Internal evaluation)

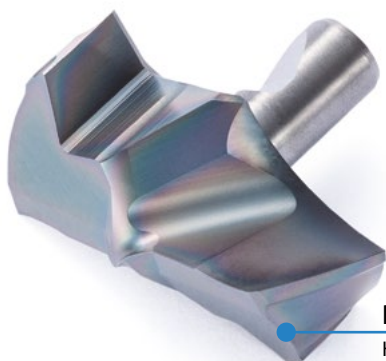
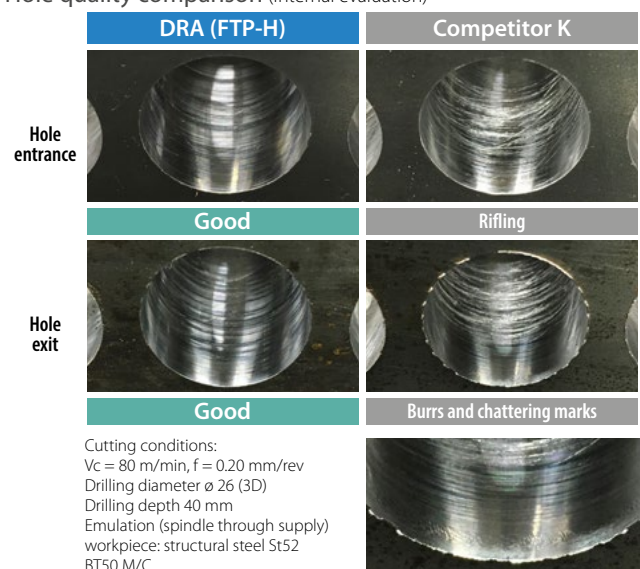

Reinforced chamfer
Higher rigidity of insert

FTP-H has excellent properties providing superior hole accuracy.

DRA insert (FTP-H - steel beam drilling) Drilling diameter $\varnothing 14.00 \sim \varnothing 26.00$



Uncut area remains in blind hole due to chamfer on the shoulder part

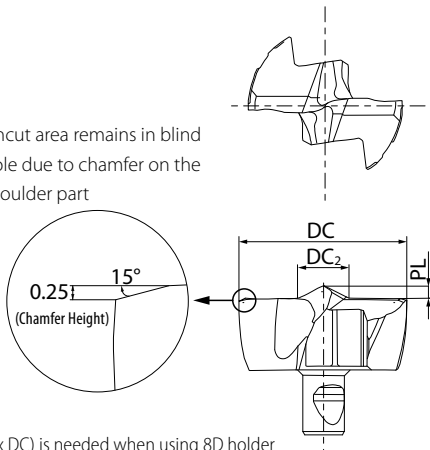

k8 tolerance

DC	k8(mm)
14.00 ~ 18.00	+0.027 0
20.00 ~ 26.00	+0.033 0

k8 is the dimension tolerance of the insert
It is not the tolerance of the cutting diameter

Note
Applicable to 1.5D, 3D, 5D and 8D holders, Prepared hole (0.5 x DC) is needed when using 8D holder

1st recommendation

Steel / PR1535

Insert

Description	Dimensions (mm)			Grade PR1535	Applicable toolholder
	DC	DC ₂	PL		
DA1400M-FTP-H	14	4.20	0.60	●	SS16-DRA140M-○ SF16-DRA140M-○
DA1600M-FTP-H	16	4.60	0.70	●	SS18-DRA160M-○ SF20-DRA160M-○
DA1800M-FTP-H	18	5.00	0.80	●	SS20-DRA180M-○ SF25-DRA180M-○
DA2000M-FTP-H	20	5.70	0.90	●	SS25-DRA200M-○ SF25-DRA200M-○
DA2100M-FTP-H	21	6.00	0.95	●	SS25-DRA210M-○ SF25-DRA210M-○
DA2200M-FTP-H	22	6.40	1.00	●	SS25-DRA220M-○ SF25-DRA220M-○
DA2400M-FTP-H	24	6.80	1.10	●	SS25-DRA240M-○ SF25-DRA240M-○
DA2600M-FTP-H	26	7.00	1.20	●	SF25-DRA250M-○ SS32-DRA250M-○



Full lineup

Please note that the insert DA2600M-FTP-H should be mounted on toolholder size S...-DRA250M-○ type only.

Inserts sold in 1 piece boxes
●: Available

Case Study

Structure part S355

Vc = 80 m/min (n = 979 min⁻¹),
f = 0.2 mm/rev (Vf = 196 mm/min),

Drilling depth 15 mm, through-hole
Coolant = Oil mist lubrication

SF25-DRA250M-3
DA2600M-XFTP PR1535

Competitor K: $\varnothing 26$ -3D

**FTP-H achieved tool life of 45 m
without any problem.**

**Shortened process time.
Good chip control.**



DRA Toolholder $\varnothing 7.94$ mm - 33.00 mm

1.5D

3D

5D

8D



(Straight shank)



(with flange)

12D



NEW

Double margin type

High-precision Insert for steel machining

HQP

Special two-step bottom and double margin
Reduces shock for higher-precision machining of steel



Drilling diameter
 $\varnothing 7.94 \sim \varnothing 19.9$

PR1525

For difficult-to-cut materials/
Stainless steel machining

HQS

Special two-step bottom and double margin
Improving stability of difficult-to-cut materials and stainless steel during machining operations



Drilling diameter
 $\varnothing 8.00 \sim \varnothing 19.5$

PR1535

General purpose

For steel/stainless steel machining
1st recommendation

GM

For a wide range of drilling applications
Special chisel edge reduces thrust force and controls vibration
Excellent hole accuracy



Drilling diameter
 $\varnothing 7.94 \sim \varnothing 33$

PR1535

PR1525

For counterboring

FTP

Solves problems at counterboring
Improved hole accuracy with pilot point geometry and double margin specifications



Drilling diameter
 $\varnothing 8.00 \sim \varnothing 25.4$

PR1535

PR1525

Case Study

Structure part S390

$V_c = 50.2$ m/min ($n = 888$ min⁻¹),
 $f = 0.247$ mm/rev ($V_f = 220$ mm/min),

Drilling depth 40 mm, through-hole
Coolant = MQL

SF25-DRA180M-5
DA1800M-GM PR1535

Competitor K: $\varnothing 18$ -5D



Competitor K

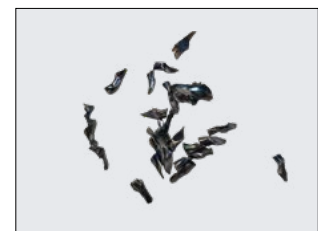

DRA

DRA produced finer chips and maintained stable machining and excellent surface finish with less cutting noise.

(User evaluation)

THIEME

Königsfelder Str. 33
58256 Ennepetal

Tel.: 0 23 33 / 97 86-0
Fax: 0 23 33 / 97 86-49

<https://thieme-werkzeuge.de>
info@thieme-werkzeuge.de